



INSTALLATION AND OPERATION GUIDE FOR

HARGROVE GAS LOGS



For all models tested through CSA International to ANSI Z21.60-2000/CGA 2.26-M96 Standards
For model number and CSA seal refer to attached nameplate.

MILLIVOLT

Installation and service must be provided by a qualified installer, service agency or the gas supplier.

NOTE: ADEQUATE FIREPLACE VENTILATION IS REQUIRED FOR SAFETY.
READ INSTRUCTIONS FULLY BEFORE INSTALLING OR OPERATING.
INSTALLER: LEAVE THESE INSTRUCTIONS WITH CONSUMER!

Hargrove Manufacturing Corporation uses refractory concrete to create the ceramic logs. Each log is hand finished to assure the most realistic, detailed logs available. The gas log burner system is designed to simulate wood burning with a yellow smoky flame. For this reason the gas log set must be burned only in a fully vented, non-combustible fireplace with the damper completely open and the chimney free of any obstructions or restrictions. The fireplace must be designed and approved to burn wood.

The realistic yellow flame produces carbon monoxide and soot. Under normal conditions, these products are exhausted up the chimney. If fumes or soot, from the gas burning, are evident in the room when the damper is fully open it indicates that the fireplace draft is defective. Do not operate your gas log set until the fireplace draft is corrected.

FOR YOUR SAFETY

Do not store or use gasoline or other flammable vapors and liquids in the vicinity of this or any other appliance.

FOR YOUR SAFETY

WHAT TO DO IF YOU SMELL GAS

1. Do not try to light any appliance.
2. Do not touch any electrical switch; do not use the phone in your building.
3. Immediately call your gas supplier from a neighbor's phone. Follow the gas supplier's instructions.
4. If you cannot reach your gas supplier, call the fire department.

WARNING: If the information in this manual is not followed exactly, a fire or explosion may result causing property damage, personal injury or loss of life.

It is the homeowner's responsibility to assure their fireplace has adequate draft.

RECOMMENDED BURN-IN PERIOD

Hargrove gas logs are made of special refractory materials, which withstand high temperatures. One characteristic of this material is retention of moisture. For this reason, we recommend burning the logs for only fifteen minutes during the first burning. After allowing the logs to cool for at least one hour, the set can be burned for any length of time.

WARRANTY

Hargrove gas logs carry a limited lifetime warranty against breakage in the original fireplace. Warranty does not include labor. This warranty is void if breakage is caused by excessive handling after burning. All accessories and metal parts carry a two-year limited warranty in the original fireplace. HARGROVE will replace items during this period for the cost of shipping.

IMPORTANT INFORMATION

WARNING: This burner assembly contains an orifice specifically for the input gas and Btu rating. Modifying or failure to use the factory orifice may cause property damage, personal injury or loss of life.

1. Do not use natural gas for propane models or propane gas for natural gas models.
2. There are many different local codes for gas fire logs. The installation and the provision for combustion and ventilation air must conform with local codes and, or in the absence of local codes, with the National Fuel Gas Code ANSI Z223.1 – (most current revision)
3. Gas log sets must be installed by personnel qualified for installing gas appliances.
4. This appliance must be installed only in a solid-fuel burning fireplace with a working flue and constructed of noncombustible materials. Solid fuels are not to be burned in a fireplace where the decorative appliance is installed.
5. A permanent free opening must be provided by either the fireplace chimney or chimney damper to vent flue gasses. Any chimney damper must be fixed in a manner, which will maintain the permanent free opening at all times. Use Table II to determine the minimum permanent free opening based on chimney height and the appliance Btu input rating. Refer to the Damper Stop section for additional directions.
6. The minimum free opening is based only on two factors; chimney height and Btu input rating. Many other factors affect the fireplace drafting. It is the homeowner's responsibility to assure their fireplace has adequate draft. If fumes or soot from the gas burning are evident in the room when the damper is fully open, it indicates that the fireplace draft is defective. Do not operate your gas log set until the fireplace draft is corrected. Consult your fireplace specialist.
7. A fireplace screen must be in place when the appliance is operating and, unless other provisions for combustion air are provided, the screen shall have an opening(s) for introduction of combustion air.
8. When glass fireplace doors are used, always operate gas log set with the doors fully open to allow for proper combustion air and to keep control valves from overheating.
9. The minimum inlet supply pressure for the purpose of input adjustment is 3.5 inches natural gas/8 inches propane in water column. The maximum inlet supply pressure is 10.5 inches natural gas/13 inches propane in water column.
10. The appliance and it's individual shut-off valve must be disconnected from the gas supply piping system during any pressure testing of that system at test pressures in excess of 1/2 psig (3.5kPa). The appliance must be isolated from the gas supply piping system by closing it's manual valve during pressure testing equal to or less than 1/2 psig (3.5kPa).
11. The fireplace chimney or venting system should be examined annually and cleaned as required by a qualified agency.
12. After burning for several hours the logs become fragile and should not be handled. Knocking or rubbing logs can cause concrete to crumble and is not covered under the warranty.
13. To clean the logs, use a soft dry paintbrush for periodic dusting of the gas fire logs. Special care must be taken to clean Birch logs. Rubbing will remove soot but will also remove the white pigments.
14. To clean the burner, shut off the gas supply, remove burner pan media, and vacuum gas ports. After cleaning, replace burner pan media and light pilot according to the lighting instructions.

FIREPLACE SIZES

Each gas log set requires a minimum 16-inch front opening height and minimum 16-inch depth. To determine the largest set that will fit in a fireplace, the width at the center of the fireplace is the critical dimension. Table I below indicates the minimum center width for each size set.

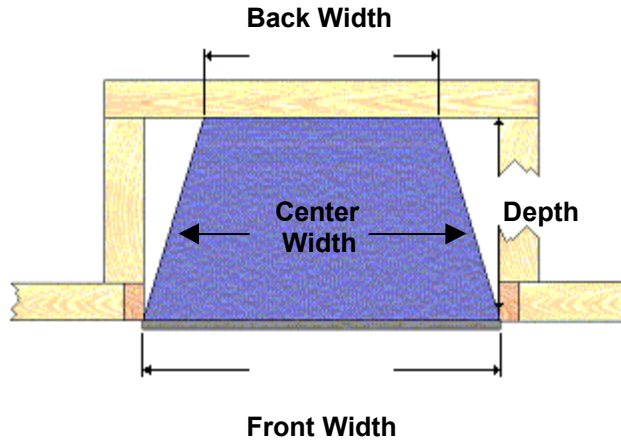

*View is looking down on the fireplace floor. To determine center width, add front width to back width and divide by 2.

TABLE I

<u>Set Size</u>	<u>Minimum Center Width</u>	<u>Minimum Front Opening Width</u>	<u>Minimum Depth</u>	<u>Minimum Height</u>
18-21	28"	30"	16"	16"
24	32"	36"	16"	16"
30	37"	42"	16"	16"
36	42"	48"	16"	18"

TABLE II

Free opening area of chimney damper for venting combustion products from decorative appliances for installation in vented fireplaces. Minimum size of chimney flue is 8" diameter.

Minimum Permanent Free Opening, Square Inches.

29	39	51	64
----	----	----	----

Chimney Height, Feet	Appliance Input Rating, Btu Per Hour (w)			
6	34,000	46,400	62,400	80,000
8	37,000	50,400	68,000	86,000
10	40,400	55,800	74,400	96,400
15	44,600	62,400	84,000	108,800
25	50,400	68,400	94,000	122,200
30	55,200	76,800	105,800	138,600

INSTALLING HARGROVE GAS LOGS

PARTS LIST

	<u>18 – 21” Set</u>	<u>24” Set</u>	<u>30” Set</u>	<u>36” Set</u>
1. Pedestal Grate	PG-16 5/8	PG-20 5/8	PG-25 5/8	PG-30 5/8
2. Ember Burner	EB-14	EB-18	EB-22	EB-26
3. Sand Natural Gas	SD	SD	SD	SD
Vermiculite LP Gas	VM	VM	VM	VM
4. Fire Embers	EM	EM	EM	EM
5. Aluminum Connector	AC-18	AC-18	AC-18	AC-18
6. RobertShaw Pilot Control	RSMV	RSMV	RSMV	RSMV
RobertShaw Control LP	RSMV-LP	RSMV-LP	RSMV-LP	RSMV-LP
7. Pilot Burner Natural Gas	RSTPGNG-18	RSTPGNG-18	RSTPGNG-18	RSTPGNG-18
Pilot Burner LP Gas	RSTPGLP-18	RSTPGLP-18	RSTPGLP-18	RSTPGLP-18
8. Volcanic Cinders	VC	VC	VC	VC
9. Damper Stop	DS	DS	DS	DS
10. Burner Orifice Natural Gas	BO-27	BO-20	BO-11	*SWEDGE
Air Mixer LP Gas	AM-50	AM-44	AM-41	AM-34
11. Fire Logs Not Shown				
12. Grate Clips 2 Required	GC 5/8 (2)	GC 5/8 (2)	GC 5/8 (2)	GC-5/8 (2)
13. Heat Shield for RSC valve	HSRS	HSRS	HSRS	HSRS

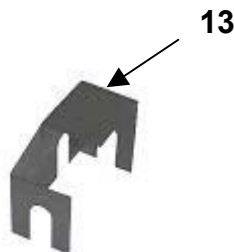
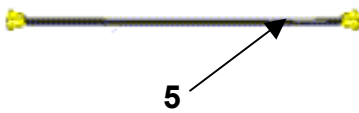
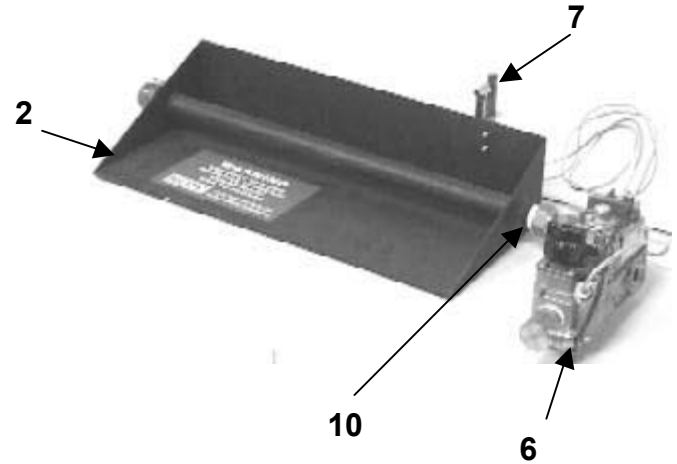
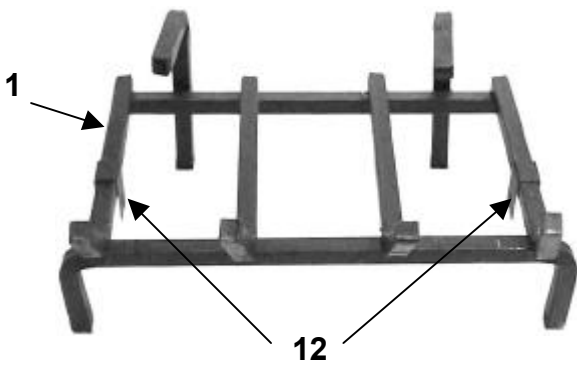

4

DAMPER STOP

Attach the **damper stop** clamp to the fireplace damper blade. Position the clamp to prevent full closure of the fireplace damper blade.

(See **Figure 1**)

If the damper stop provided does not fit, the installer shall install a permanent damper stop that will keep the damper open to a minimum opening as determined in **TABLE II**. (See Item 6 of Important Information)



CAUTION

THE MINIMUM PERMANENT FREE OPENING MUST BE MAINTAINED AT ALL TIMES.

EMBER BURNER POSITIONING

1. Turn gas **off**.
2. Remove old log lighter, ashes and other material from the firebox.
3. Center the **ember burner** on the fireplace floor with the burner pipe completely visible from the front. For best results the ember burner should be directly under the flue opening with a minimum of 4" from the front edge of the ember burner to the fireplace opening.
4. Place the **Pedestal Grate** over the ember burner so that the slits in the **Grate Clips** fit over the back wall of the ember burner pan. Once the final positioning is established, mark the burner and grate position on the floor of the fireplace for reference points. Remove the grate and proceed with the gas connection. (See **Figure 2**)

GAS CONNECTION

1. The gas supply line should be 1/2" Inside Diameter (ID) up to 30 feet and 3/4" for longer distances.
2. Tighten the black pipe cap on the end of the burner pan pipe.
3. Use the **Aluminum Connector** to connect gas supply to the **RobertShaw Millivolt Valve** on the burner assembly. When bending aluminum tubing use proper bending procedures to avoid kinking the tube. Do not use corrugated flexible tubing, it may cause a whistling noise.
4. Read lighting instructions. Light pilot and check for leaks using soapy water. These controls are factory present and will not normally require additional adjustment of the pilot flame. If field adjustment of the pilot flame is required, remove the pilot adjustment cover screw to expose the adjusting screw. Turn the adjusting screw clockwise  to reduce the flame, or counterclockwise  to increase flame. Replace pilot adjustment cover screw and tighten securely. Light main burner and check for leaks using soapy water.

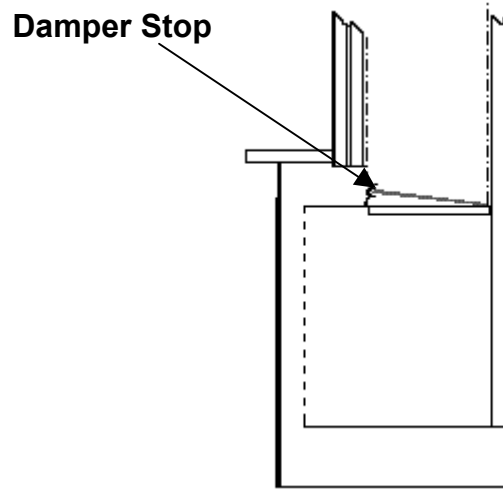

Figure 1

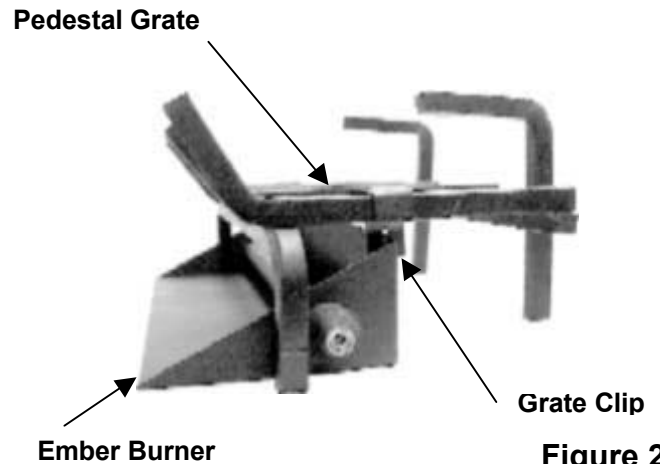

Figure 2

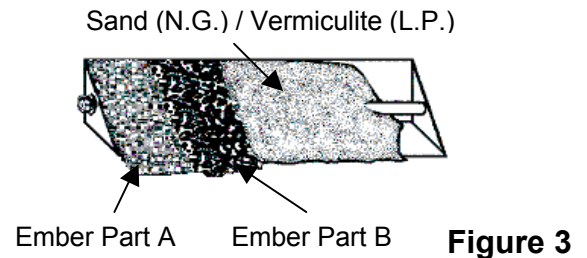

Figure 3

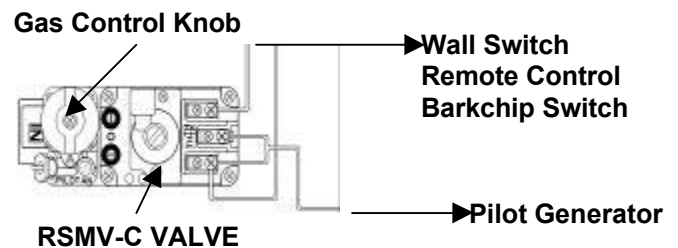

Figure 4

SWITCHING DEVICES

1. To install the wall switch mount a standard 3" x 2" electrical box in the wall near the fireplace. Run the thermostat wire from the electrical box to the millivolt valve. At the valve, connect the lead wires to the two outside terminals labeled "TH". On the switch, connect lead wire to each terminal. (**Figure 4**)

BURNER PAN MEDIA

1. Fill the burner pan with **Sand (Vermiculite** if using LP gas). Sand level should be sloped evenly with the sides of ember burner. Burner should be completely full.
2. Light the gas and observe flame for even distribution.
3. **Embers (Rockwool)** are placed over the sand to simulate glowing embers. For best results pinch off pieces of the rockwool the size of a dime and feather it out. Place as much as desired over the area the gas comes through. (See **Figure 3** on previous page.)

PILOT LIGHT

The **pilot light** should be checked periodically to assure proper flame. On the EB burner pans the flame should be directly over the back of the ember burner pan. The ember burner pan will be permanently positioned in relation to the grate.

GRATE PLACEMENT

Place the **pedestal grate** over the ember burner using the reference marks made on the fireplace floor earlier such that the two holes in the ribs of the grate are directly over the back of the ember burner pan. The ember burner pan will be permanently positioned in relation to the grate.

LOG PLACEMENT

1. The longest log is the **front log**. It should be placed on the front of the grate with the flat, unfinished side facing back. The 3/8" diameter white paint dots should be pointing up.
2. The second longest log is the **back log**. It is placed on the back pedestal of the grate with the 3/8" diameter white paint dot pointing up.
3. The top logs should be placed over the 3/8" white paint dots and positioned as shown on the drawings on the last pages of the instruction.
4. The bottom of the twigs (small 7-10" logs) should be placed over the 3/8" white paint dots and positioned as shown in the drawings on the last pages of the instruction. (See also **Figure 7**)

VOLCANIC CINDERS

The black **volcanic cinders** are used to cover the fireplace floor, fittings and tubing around the burner system. Although not functional, the black cinders act as a picture frame to show off the glowing embers and yellow flame.

FOR YOUR SAFETY

Do not use this appliance if any part has been under water. Immediately call a qualified service technician to inspect the appliance and to replace any part of the system or gas control, which has been underwater. Keep this appliance area clear and free from combustible materials, gasoline, and other flammable vapors and liquids.

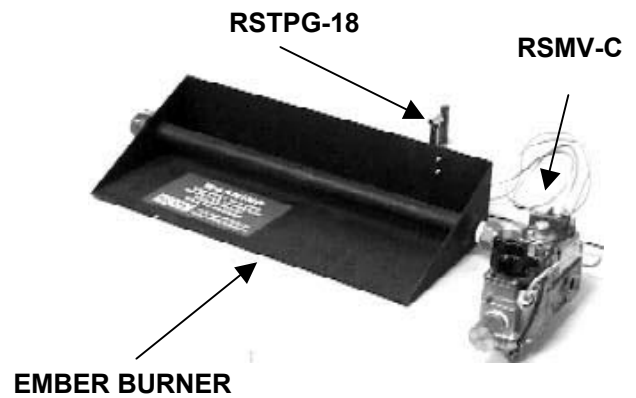
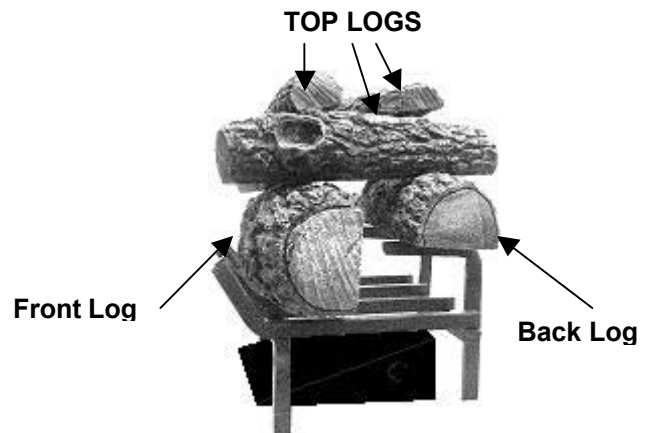
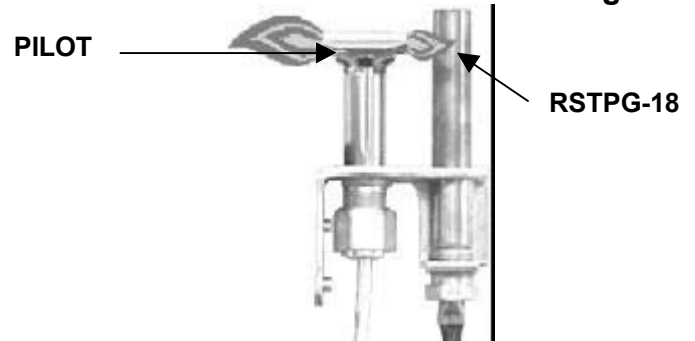

Figure 5



FOR YOUR SAFETY READ BEFORE LIGHTING

WARNING: If you do not follow these instructions exactly, a fire or explosion may result causing property damage, personal injury or loss of life.

- A. This appliance has a pilot, which must be lit by hand. When lighting the pilot, follow these instructions exactly.
- B. BEFORE LIGHTING smell all around the appliance area for gas. Be sure to smell next to the floor because some gas is heavier than air and will settle on the floor.

WHAT TO DO IF YOU SMELL GAS:

- *Do not try to light any appliance.
- *Do not touch any electric switch; do not use any phone in your building.
- *Immediately call your gas supplier from a neighbor's phone. Follow the gas supplier's instructions.
- *If you cannot reach your gas supplier, call the fire department.

- C. Use only your hand to push in or turn the gas control knob. Never use tools. If the knob will not push in or turn by hand, do not try to repair it. Call a qualified service technician. Force or attempted repair may result in a fire or explosion.
- D. Do not use this appliance if any part has been under water. Immediately call a qualified service technician to inspect the appliance and to replace any part of the control system or gas control which has been under water.

LIGHTING INSTRUCTIONS

1. **STOP!** Read the safety information above on this label.
2. Push in gas control knob slightly and turn clockwise  to "OFF".

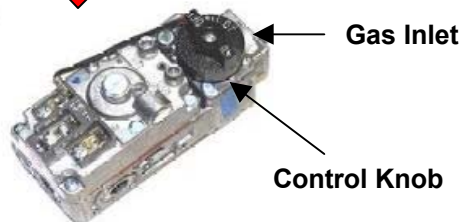

NOTE: Knob cannot be turned from "PILOT" to "OFF" unless knob is pushed in slightly. Do not force the knob.

3. Wait five (5) minutes to clear out any gas. If you then smell gas, STOP! Follow "B" in the safety information above on this label. If you don't smell gas, go to next step.

4. Find the pilot – follow the metal tube from gas control behind the burner pan.

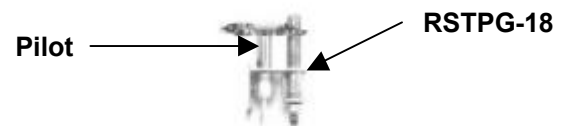

5. Turn knob on gas control counterclockwise  to "PILOT".
6. Push in control knob all the way and hold in. Immediately light the pilot with a match. Continue to hold the control knob in for about one (1) minute after the pilot is lit. Release knob and it will pop back up. Pilot should remain lit. If it goes out, repeat steps 3 – 7. If knob does not pop up when released, stop and immediately call your service technician or gas supplier. If pilot will not stay lit after several tries, turn the gas control knob to 'OFF' and call your gas supplier.

LIGHTING INSTRUCTIONS

Push in gas control knob slightly and turn clockwise  to "OFF". Do not force control knob

LIMITED WARRANTY

Refractory Logs

Hargrove gas logs carry a limited lifetime warranty against any manufactured defect or breakage when installed indoors. A replacement will be available from the dealer at which the appliance was purchased. This warranty does not cover breakage caused by excessive handling once installed and fired. Outdoor applications carry a one (1) year limited warranty.

Burner & Grate

If the burner or grate fails due to deterioration within two (2) years of the verified purchase date, a free replacement will be made available from the dealer at which the appliance was purchased.

Valves, Remote Controls, & Switching Devices

Hargrove warrants all valves, remote controls and switching devices against manufacturing defects, which appear within two (2) years of the verified purchase date. Warranty does not cover products that have been damaged by misuse from overheating. Before any product is returned a Return Goods Authorization number (RGA) must be issued by Hargrove's Customer Service Department. All returns must be accompanied by an explanation of the problem and all necessary parts.

All Other Parts

If any assembled part should fail to operate or be found defective which appear within two (2) years of the verified purchase date, a replacement will be available from the dealer at which the appliance was purchased.

Buyer shall notify Hargrove Mfg Corp. of any defect covered by this warranty no later than thirty (30) days after defect is discovered. Failure to provide notice within thirty (30) days shall void the limited warranty.

WHAT IS NOT COVERED

1. Removal and reinstallation costs.
2. Labor costs for replacement or repairs.
3. Transportation or shipping cost.
4. The cost of a service call to diagnose trouble.
5. Painted Surfaces.
6. Damage or defect caused by improper installation, accident, misuse, abuse, alteration, or authorized service technician.
7. Replacement of burner or combustion chamber resulting from improper storage of the appliance.

LIMITATIONS AND EXCLUSIONS

1. No one has authority to add to or vary this limited warranty, or to create for Hargrove Manufacturing Corporation any other obligation or liability in connection with this appliance.
2. Any implied warranty applicable to this appliance is limited in duration to the same period of time as this written Warranty. Some states do not allow limitations on how long an implied warranty lasts, so the above limitations may not apply to you.
3. HARGROVE MANUFACTURING CORPORATION WILL NOT BE LIABLE FOR INCIDENTAL, CONSEQUENTIAL, SPECIAL OR CONTINGENT DAMAGES YOU MIGHT SUFFER AS A RESULT OF A CLAIM UNDER THIS WRITTEN WARRANTY OR ANY IMPLIED WARRANTY. Some states do not allow the exclusion or limitation of incidental or consequential damages, so the above limitations or exclusion may not apply to you.
4. This warranty applies only to the original purchaser and may not be transferred or assigned.
5. If you cannot verify the purchase date of the appliance, the warranty period will begin on the date of which the appliance was manufactured.
6. Replacement or repair parts are warranted for the remaining period of the original part warranty. Warranty parts must be obtained through authorized dealers of this product who will provide original factory replacement parts. Failure to use original factory replacement parts voids this warranty.
7. The maximum liability of Hargrove Mfg Corp. in connection with this limited warranty shall not in any case exceed the contract price paid for the product claimed to be defective or unsuitable.
8. Purchaser or user agrees to hold Hargrove Mfg Corp. harmless from any and all claims by the buyer as a result of injury or damage to an ultimate user or other person caused by the product sold herein by the seller to the buyer, whether the injury or damage results from the assembly, installation, operation, shipment, storage, or manufacture of this product. Hargrove Mfg Corp. makes no warranties, expressed or implied, other than those expressly stated herein.

YOUR DUTIES

This appliance must be installed by a qualified installer, operated and maintained in accordance with all applicable codes and the instructions furnished with the appliance. You must provide a receipt verifying the purchase date of the appliance when making a warranty claim with the dealer from which the appliance was purchased.

This warranty gives you specific legal rights, and you may also have other rights, which vary from state to state.

To register your Hargrove product, please visit our website at <http://www.hargrovegaslogs.com/reg.htm>.

CONTACT INFO: Hargrove Manufacturing Corp.

Tele: (800) 725-4166